

1

2

3

4

A

B

C

D

E

F

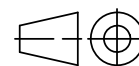
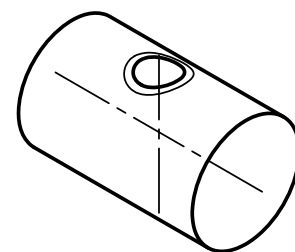
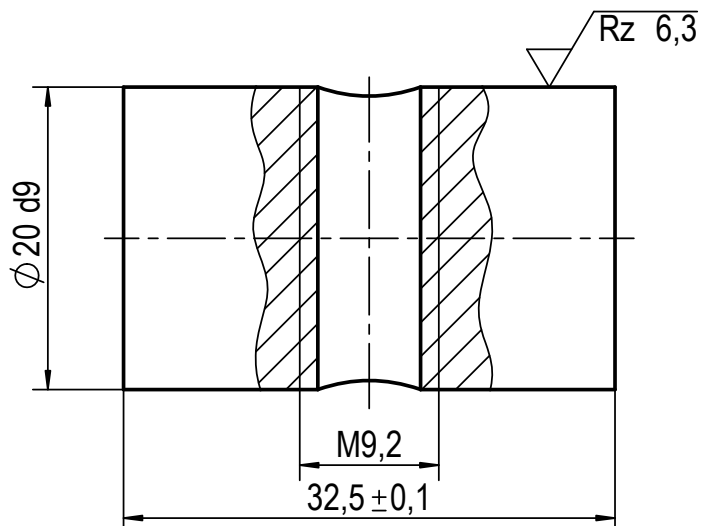

20d9	19,935	19,883
Passmaß	Höchstn.	Mindestm.

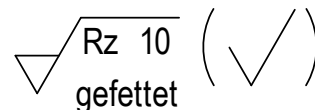
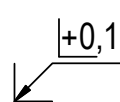
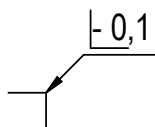

Allgemeintoleranz ISO 2768- mH

M 2:1 (1:1)

Verantwortl. Abt. NWS- MB	Technische Referenz	Erstellt durch NWS- MB	Genehmigt von	Werkstoff AlCu4PbMg
		Dokumentenart Fertigungszeichnung		Dokumentenstatus freigegeben
		Titel, zusätzlicher Titel Bolzen mit Gewinde		NWS 100- 00- 04
Änd. A	Ausgabedatum	Spr. de	Blatt 1	