

1 2 3 4

A

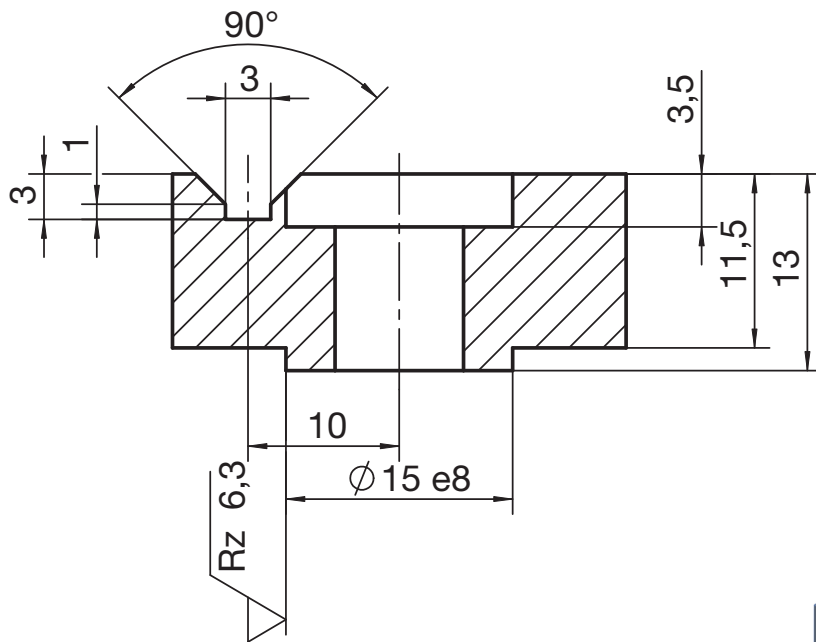

B

C

D

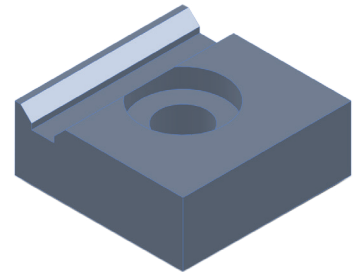
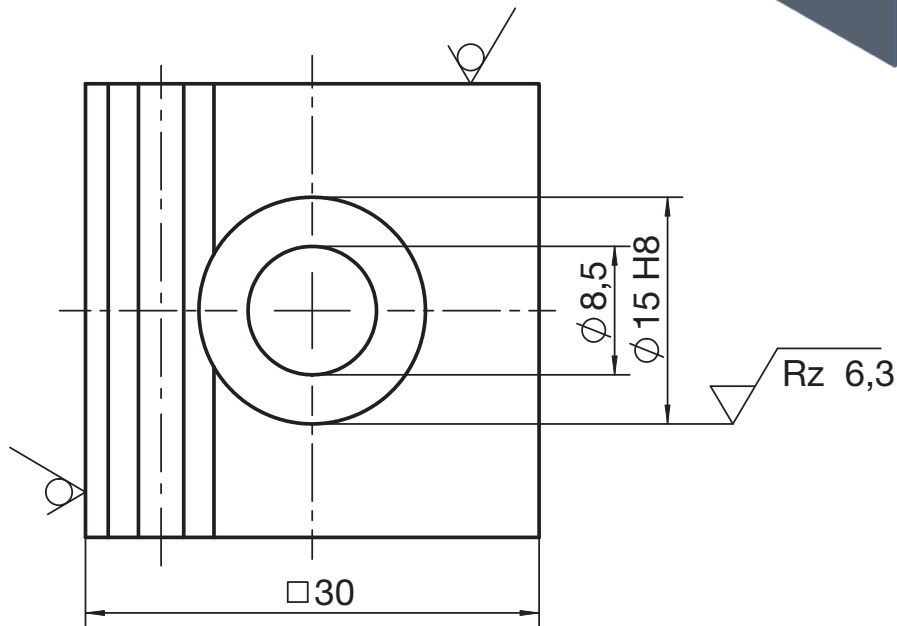

E

15e8	14,968	14,941
15H8	15,027	15,000
Passmaß	Höchstm.	Mindestm.

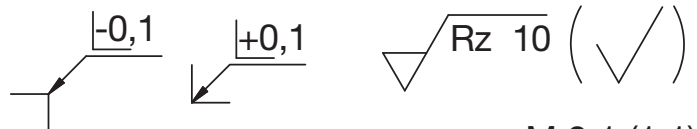

Allgemeintoleranz ISO 2768-mH

M 2:1 (1:1)

F

Verantwortl. Abt. NWS MB	Technische Referenz	Erstellt durch NWS MB	Genehmigt von	
 Nachwuchsstiftung Maschinenbau	Dokumentenart Fertigungszeichnung		Dokumentenstatus freigegeben	
	Titel, zusätzlicher Titel Nadelhalterung Unterteil		NWS 100-00-04/1	
	Änd. A	Ausgabedatum	Spr. de	Blatt 1